

HYRAX®

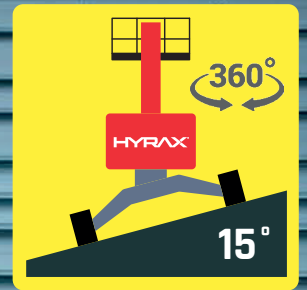

Specifications Model 27.12

Version: 04-2021

Pushing the limit

 **SCHULER & SCHULER AG**
HEBE- UND TRANSPORTECHNIK
CH-6405 Immensee (SZ) contact@schuler-schuler.ch
Telefon +41 41 854 7000 Telefax +41 41 854 7001
www.schuler-schuler.ch

Specifications

Model 27.12

hyraxindustries.com

Productivity

Working height:	12,6 m
Platform height:	10,6 m
Horizontal reach:	8,75 m
Travel height:	12,6 m
Platform capacity:	270 kg
Platform rotation:	180°
Vertical jib rotation:	180°
Continuous turntable rotation:	360°
Driving speed (stowed):	0 - 4,0 km/h
Driving speed (raised):	0 - 2,0 km/h
Gradeability:	45% = 25°
Automatic bi-leveling:	15° / 15°

Measurements

Machine	Stowed (l x w x h):	4565 x 1750 x 1996 mm
	Tail swing (counter weight in):	200 mm
	Tail swing (counter weight out):	700 mm
	Total weight without options:	2750 kg
Undercarriage	Width stowed:	1750 mm
	Width extended:	2200 mm
	Ground clearance tracks folded:	174 mm
	Ground clearance tracks extended:	278 mm
Platform	Measurements (l x w x h):	1400 x 720 x 1100 mm
	Entry width:	647 mm
	Entry height:	920 mm
	Step in height:	400 mm

ATD

18,5kW 3 cil. kubota diesel engine

ATD^{eu}

18,5kW 3 cil. kubota diesel engine
Electric plug-in drive motor 230V / 380V

ATE

Fully lithium powered
20kWh / 30kWh battery packs

Mechanical

43 liter fuel tank capacity (ATD)
Fully proportional controls
Loadsensing hydraulic pump
2 speed track motors
Automatic proportional RPM controller

Safety Features

Approval for EN280 / CE
Tilt alarm
LED flashing lights on rear
Overhead safety crush prevention
Integrated weight system in platform
12V emergency lowering pump
Dual top railing on basket
Horn

Options

6,5 kVA-230V AC generator for power in platform (ATD)
Foldable load carriers on platform (70KG)
Extra screw trays
Holder for spray cans
Adjustable work lights on platform
4 x led work lights on main frame
Led flood light under platform
Non-marking rubber tracks (grey)
Water level holder in platform
Pail hanger in platform
Solar panel installation basket incl. load carriers and clamps
Additional counter weights: 81kg, 124kg, 160kg and 230kg
HY-Link portal communications, online diagnostics

Custom color configurations possible

Engine covers
Platform
Jib assembly
Boom outer part 1
Boom inner part 2

Working range diagram

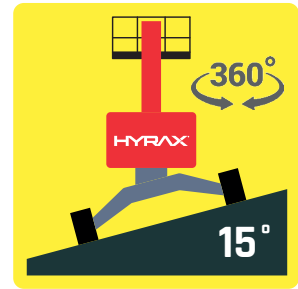
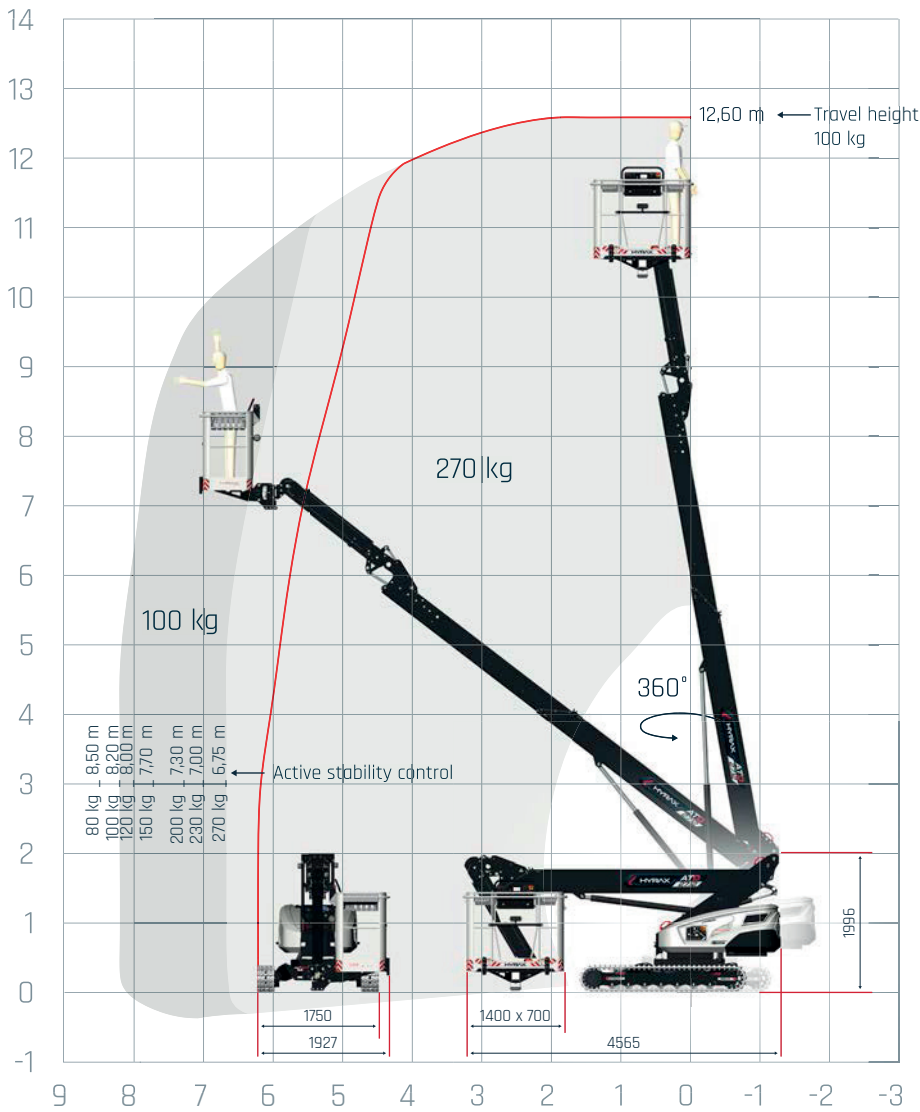
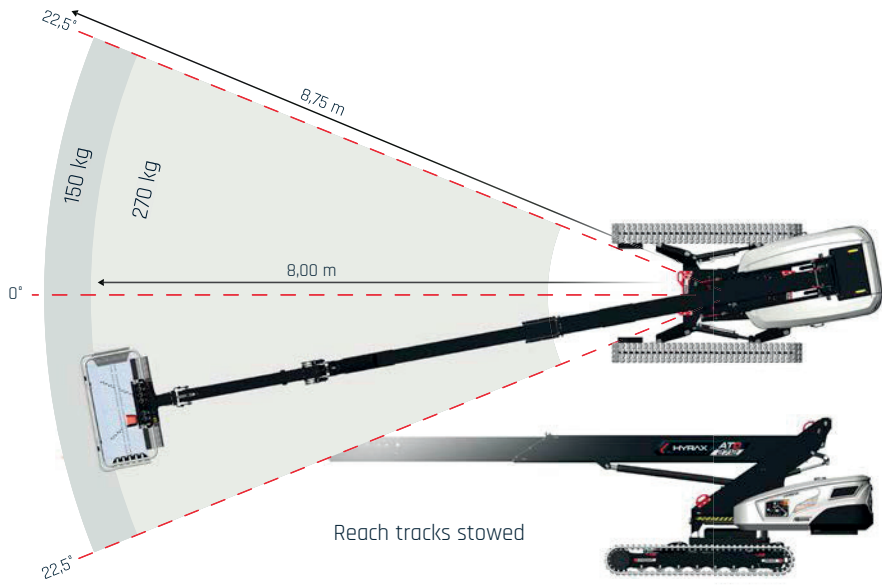

Hyrax Industries BV. Has the policy to continuously improve their products.
Product specifications are subject to change without prior notice and can be changed without obligation.